



Sabaragamuwa Provincial Department of Education – Weekly School

Grade 10

Information & Communication Technology

P. V. U. I. Gunarathne - KG/Dehi/ Rajasinghe C. C

Competency 2 : Selects and uses computer hardware.

Competency Level 2.1 : Classifies computers using a variety of methods.

Study the text book from page number 37 to 50 in the second lesson and answer the following questions.

1. Complete the following table.

Input Devices			Output Devices
Pointing Devices	Imaging and Video Input Devices	Scanners	

mouse,monitor , Optical Character Recognition, digital camera ,Multimedia Projector flatbed Scanners, touch pad , Optical Mark Recognition – OMR ,Printer , touch screen, joy stick

2. Write devices which provide softcopy, Hardcopy and Sound.

.....  
.....  
.....

3. "LCD monitor is better than CRT monitor to use". Do agree? Justify your answer.

.....

.....

.....

.....

.....

.....

4. Classify printers.

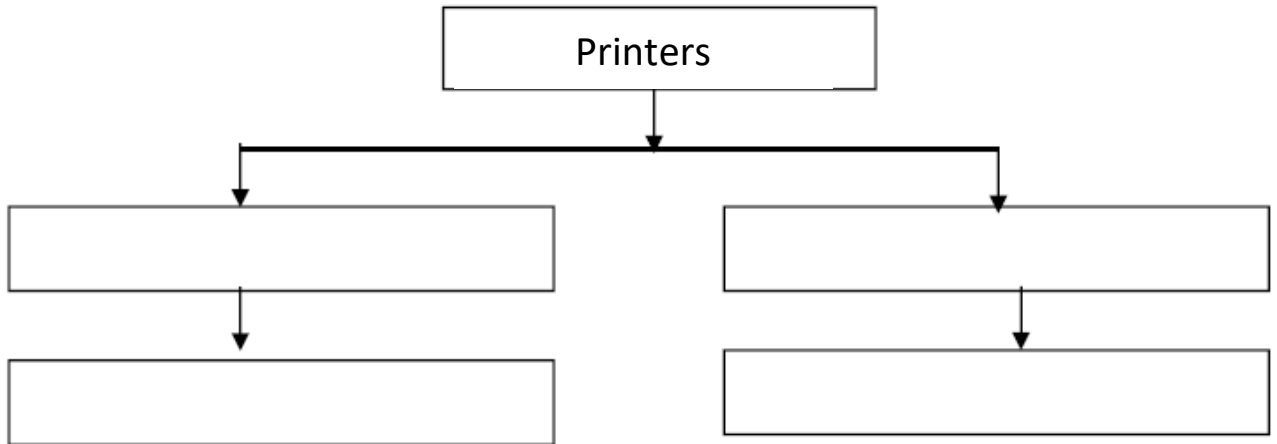

5. Classify computer memory

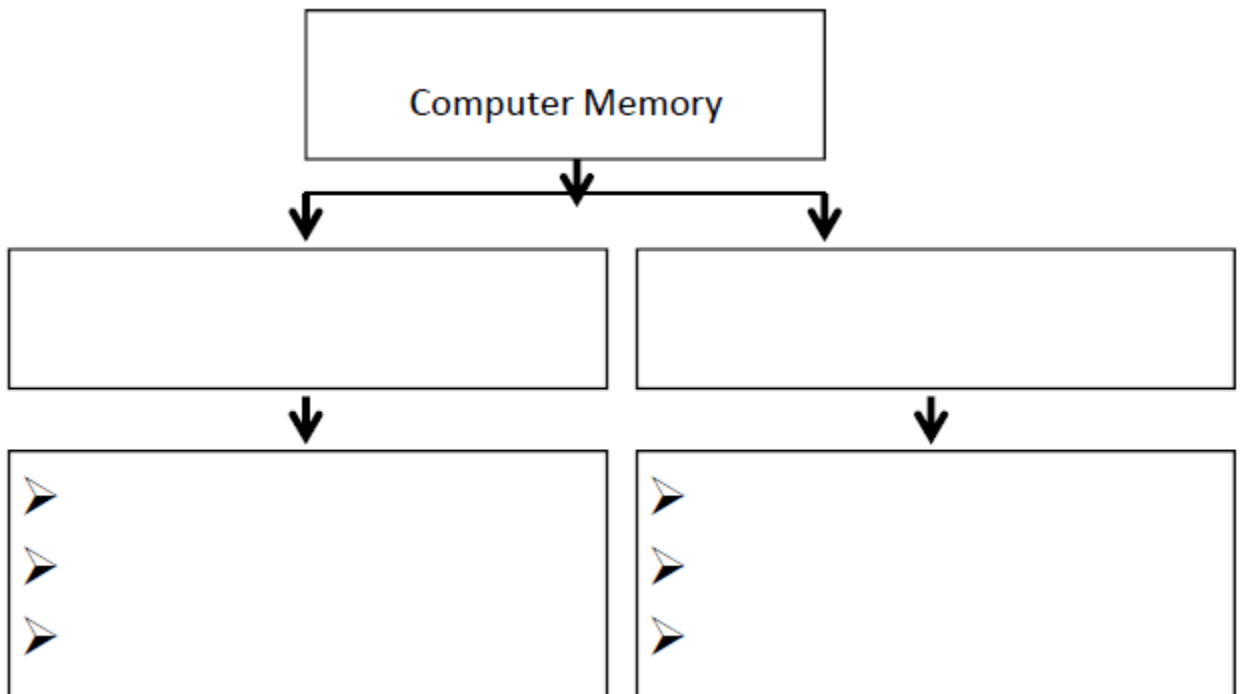

Select the correct answer

1. What is not a pointing device?
  - a. Touch Screen
  - b. Digitizer
  - c. Light Pen
  - d. Pen Drive
2. What is not a magnetic storage device?
  - i. Floppy Disk
  - ii. Tape
  - iii. Hard Disk
  - iv. Compact Disk
3. The input device, the output device and the storage device are listed in which of the following combinations, respectively?
  - i. Keyboard, Scanner, Mouse
  - ii. Scanner, Mouse, Keyboard
  - iii. Compact Disk, Keyboard, Main Memory
  - iv. Keyboard, Speaker, Compact Disk
4. The example for pointing device are,
  - a. Mouse
  - b. Scanner
  - c. Lighten Pen
  - d. Printer)

The correct answer is,

- i. a and c
  - ii. b and d
  - iii. a, b and d
  - iv. All the above
5. Random Access Memory – RAM is
  - i. A permanent memory
  - ii. A secondary memory
  - iii. A temporary memory
  - iv. All the above
6. Consider the following statements.
  - a. RAM is a volatile memory.
  - b. Hard disk is a auxiliary memory.
  - c. The capacity of floppy disk is higher than the hard disk.

The true statement is/are,

- i. a only
- ii. b only
- iii. a and b
- iv. b and c

7. A person takes a picture with a digital camera and then shows it to a friend through the display on the camera. In this case the function of the digital camera is,

- i. Input Device.
- ii. Output Device
- iii. Input / Output Device.
- iv. Communication Device

8. The clock speed of the CPU measures by

- i. Byte
- ii. Bits per seconds
- iii. Hz
- iv. Mbps

9. Consider the following memories

- a. Read Only Memory – ROM
- b. Secondary Storage
- c. Cache Memory
- d. Flash Memory
- e. Random Access Memory – RAM

Which of the above are volatile memories?

- i. a, b
- ii. a, c
- iii. c, d
- iv. c, e

10. The advantages of using liquid crystal technology computer screens instead of cathode ray tube screens is,

- i. Relatively inexpensive and getting a clear view.
- ii. Less power consumption and less space consumption.
- iii. The longer it takes to respond and the lower the price.
- iv. The screen is less shaky and more comfortable